



LITHIUM  
GASOLINE



**Snow tank volume**

1 m<sup>3</sup> / compacted 1.25 m<sup>3</sup>  
(35.3 ft<sup>3</sup> / compacted 44.2 ft<sup>3</sup>)



**Water tank volume**

340 l (89.8 gal)



**Blade width**

1,400 mm (55 1/8 in)



**Fields of operation**

Mobile / Event



# PERFECT FOR YOUR EVENT

Sporting events, ice skating at the Christmas market, in the town square or in front of your family hotel: Mobile ice rinks are the up and coming trend. With the compact WM Pinguino, cleaning and caring for smaller ice surfaces is a breeze: Perfect ice quality, and great fun guaranteed!



Tobogganing World Cup  
Deutschnofen 2019



WM Pinguino  
Dreams on Ice

*„Agile, comfortable to use and outstanding ice resurfacing: With the WM Pinguino, we create the perfect ice conditions for our events!“*



Raphael Fink  
Pond Hockey Championship  
Ritten / Italy



## HIGHLIGHT

# THE DRIVER SITS UP FRONT

Hop on and zoom off! The driver sits up front on the WM Pinguino, just like in a normal car. This makes work operations considerably easier, even for inexperienced users. The frontal seating position guarantees you a clear, all-round view and makes manoeuvring extremely simple. That means enhanced safety for people, vehicle and the venue.



- WIDE FIELD OF VISION 📏
- COMFORTABLE SEATING POSITION 📏
- EASE OF USE 📏







HIGHLIGHT

## ***BLADE CHANGE? JUST LIFT AND CHANGE!***

Blade changing is quick and easy, and the planing unit doesn't even need to be disengaged. Simply lift the planing unit, remove the blade, and you're done! Whenever the need arises the blade can be changed quickly and easily in just a few simple steps with no effort whatsoever, guaranteeing you a higher quality of ice throughout the season – to the immense joy of all skaters!



**EASY, QUICK AND PRECISE +**

**LOW INJURY RISK +**

**CONSISTENTLY HIGH ICE QUALITY +**

## ICE RESURFACING



Planing unit



Manual blade adjustment



Brush



Snow tank open



The WM Pinguino planes the ice like a large-scale pro guaranteeing top-quality ice surfacing even on mobile ice rinks, while the brushes (optional) ensure perfectly smooth edges.

**340 LITRES (89.8 GALLONS) WATER** 📌

**OUTSTANDING PLANING PERFORMANCE** 📌

**EASE OF REMOVAL** 📌



## LIGHTING



The combination of LED lighting and high-performance side lights guarantees optimum visibility at all times.

- ENERGY EFFICIENT ✚
- STYLISH INTEGRATION ✚
- GOOD VISIBILITY ✚

## MAINTENANCE

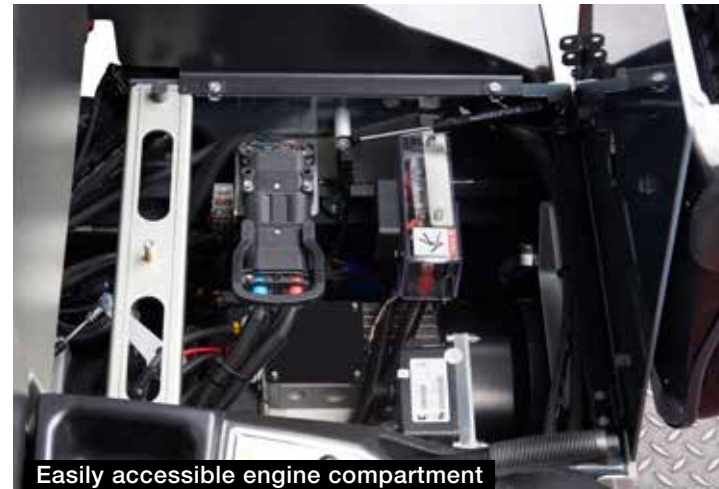

All areas of the vehicle are easily accessible, with no dismantling required. Maintenance is quick and inexpensive. Minimum operating and maintenance costs.

- EASILY ACCESSIBLE** 📌
- LOW MAINTENANCE COSTS** 📌
- RAPID SERVICE TIMES** 📌

## TRANSPORT



On to your next event? The low-weight WM Pinguino is fitted with lifting pockets for ease of transportation by forklift or trailer.

**EASE OF TRANSPORTATION** 📌

**SPACE-SAVING** 📌

**LOW WEIGHT** 📌

# LITHIUM



# FACTS & FIGURES

<b>Motor</b>	Asynchronous motor
<b>Drive power</b>	10 kW
<b>Battery Lithium</b>	BlueLi 80V – 100Ah
<b>Charger Power</b>	3 kW
<b>Battery charger connection</b>	230V / 50Hz
<b>Autonomy</b>	ca. 1h 10 min.
<b>Charging time</b>	ca. 2h 40 min.
<b>Weight when empty</b>	1,250 kg (2,755 lbs) – basic outfit
<b>Water tank</b>	340 l (89.8 gal)
<b>Snow tank</b>	1 m <sup>3</sup> (35.3 ft <sup>3</sup> ) – compacted 1.25 m <sup>3</sup> (44.2 ft <sup>3</sup> )

# INCLUDED IN DELIVERY



1 blade in transport sheath



Towel felt



2 rubber mats

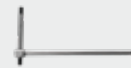

6 mm hex socket T wrench



Cross-key with nut



Laceration-proof safety gloves



Grindstone



Water connector



Fuse set



Set ABS fastening material



Operating instructions



Online spare parts catalogue

## STANDARD EQUIPMENT

<b>Transmission</b>	Continuously adjustable hydraulic four-wheel drive
<b>Axles</b>	Single wheel drive
<b>Steering</b>	Hydraulic
<b>Footbrake</b>	Hydraulic
<b>Parking brake</b>	Mechanical parking brake on rear wheels
<b>Hydraulic system</b>	18 cm <sup>3</sup> (0.004 gpm) axial piston pump for drive, 6 cm <sup>3</sup> (0.0013 gpm) work units + cylinder movements, 4.4 cm <sup>3</sup> (0.0001 gpm) steering
<b>Diameter of screw conveyors</b>	vertically ø 175 mm (6 7/8 in) horizontally ø 170 mm (6 5/8 in)
<b>Tires</b>	5.00R12 83/81P 2 rows of spikes
<b>Wheel rims</b>	12" x 5" with hubcaps

All-wheel drive
Parking brakes
2 board guide rollers
Watertank-snowbin made of stainless steel
Spring suspended drivers seat
Horn
Easily accessible engine compartment (tiltable drivers seat, hydraulically tiltable snowtank)
Hydraulic power steering
2 hydraulically powered screw conveyors
Hydraulic carriage pressure system
Hydraulic opening and closing of snow bin cover
Manual blade adjustment
Tiltable planing device for easy, safe blade changing
Tiltable operator's platform (2 positions)
1 blade
1 towel
Scope of delivery set



In conformity with Suva no. Nr. E 7164/1.e  
type-examination certificates



**Snow tank volume**  
1 m<sup>3</sup> / compacted 1.25 m<sup>3</sup>  
(35.3 ft<sup>3</sup> / compacted 44.2 ft<sup>3</sup>)



**Water tank volume**  
340 l (89.8 gal)



**Blade width**  
1,400 mm (55 1/8 in)



**Fields of operation**  
Mobile / Event

## GASOLINE



## FACTS & FIGURES

<b>Engine</b>	Honda GX690RH, 2 cylinder 688 cm <sup>3</sup> (41.9 in <sup>3</sup> )
<b>Power</b>	16.5 kW / 22.1 HP - 3,600 rpm
<b>Weight when empty</b>	1,100 kg (2,425 lbs) – basic outfit
<b>Water tank</b>	340 l (89.8 gal)
<b>Snow tank</b>	1 m <sup>3</sup> (35.3 ft <sup>3</sup> ) – compacted 1.25 m <sup>3</sup> (44.2 ft <sup>3</sup> )
<b>Fuel tank</b>	15 l (4 gal)

## INCLUDED IN DELIVERY



1 blade in transport sheath



Towel felt



2 rubber mats

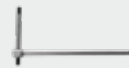

6 mm hex socket T wrench



Cross-key with nut



Laceration-proof safety gloves



Grindstone



Water connector



Fuse set



Set ABS fastening material



Operating instructions



Online spare parts catalogue

## STANDARD EQUIPMENT

<b>Transmission</b>	Continuously adjustable hydraulic four-wheel drive
<b>Axles</b>	Single wheel drive
<b>Steering</b>	Hydraulic
<b>Footbrake</b>	Hydraulic
<b>Parking brake</b>	Mechanical parking brake on rear wheels
<b>Hydraulic system</b>	18 cm <sup>3</sup> (0.004 gpm) axial piston pump for drive, 6 cm <sup>3</sup> (0.0013 gpm) work units + cylinder movements, 4.4 cm <sup>3</sup> (0.0001 gpm) steering
<b>Diameter of screw conveyors</b>	vertically ø 175 mm (6 7/8 in) horizontally ø 170 mm (6 5/8 in)
<b>Tires</b>	5.00R12 83/81P 2 rows of spikes
<b>Wheel rims</b>	12" x 5" with hubcaps

All-wheel drive
Parking brakes
2 board guide rollers
Watertank-snowbin made of stainless steel
Spring suspended drivers seat
Horn
Easily accessible engine compartment (tiltable drivers seat, hydraulically tiltable snowtank)
Hydraulic power steering
2 hydraulically powered screw conveyors
Hydraulic carriage pressure system
Hydraulic opening and closing of snow bin cover
Manual blade adjustment
Tiltable planing device for easy, safe blade changing
Tiltable operator's platform (2 positions)
1 blade
1 towel
Scope of delivery set



In conformity with Suva no. Nr. E 7164/1.e  
type-examination certificates



**Snow tank volume**  
1 m<sup>3</sup> / compacted 1.25 m<sup>3</sup>  
(35.3 ft<sup>3</sup> / compacted 44.2 ft<sup>3</sup>)



**Water tank volume**  
340 l (89.8 gal)



**Blade width**  
1,400 mm (55 1/8 in)



**Fields of operation**  
Mobile / Event

# OPTIONALS

## Wash systems

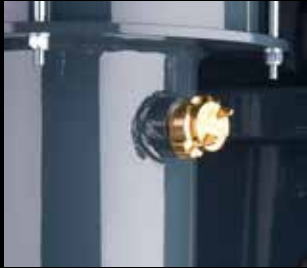

Screw conveyor wash system vertical



Screw conveyor wash system horizontal

## Dasher board processing



Brush

## Overview & security



Side mirrors front left & right



Rear-view camera



Protective guard for board guide rollers

## Comfort



Hydraulic blade adjustment



Slide extension



Water tank signage



Conveyor screw overload warning system



Acquastop valve with time relay



### Lighting



Front and working lights



Flashing warning light

### Personalization



Custom wrap 4c  
digital print

### Service



Spare wheel 12"



Diagnostic cable  
Controller



Diagnostic cable  
BMS

# DIMENSIONS

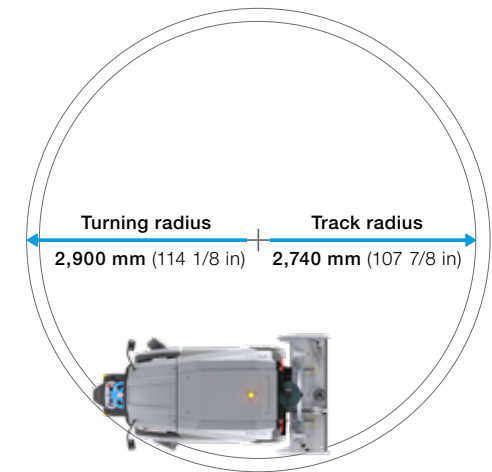
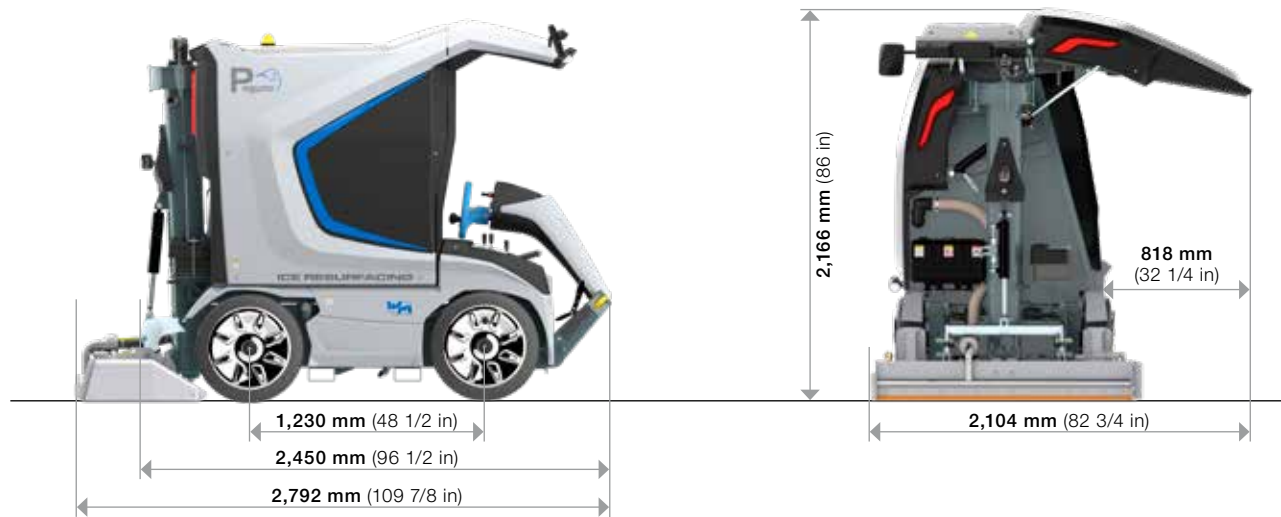
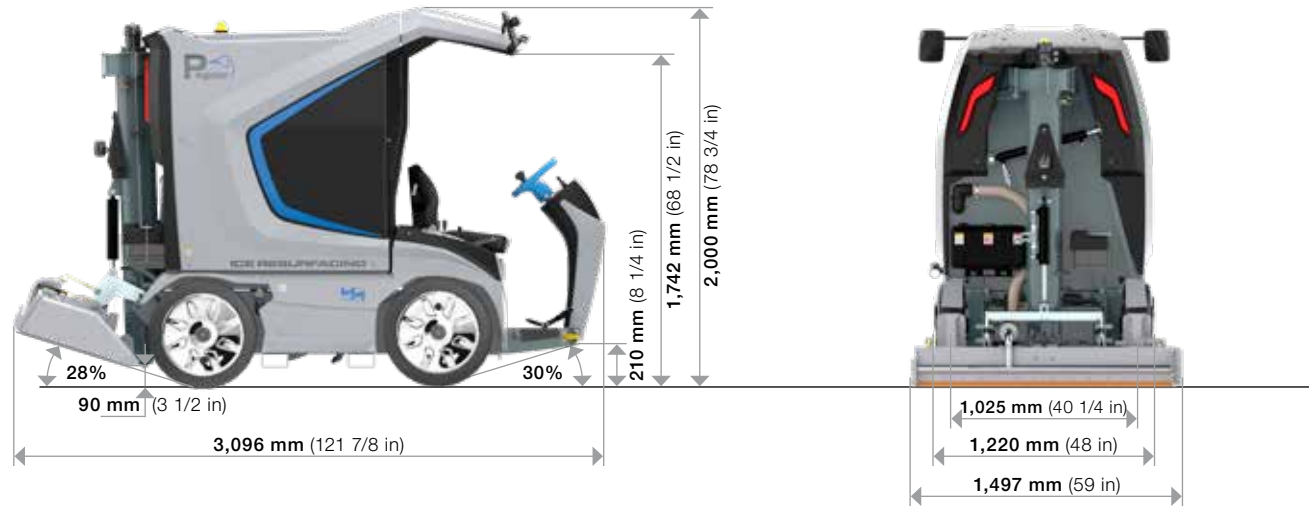



# WM PINGUINO





# OUR COMMITMENT

## User friendliness

Through the use of top-quality components together with a well-planned design, maintenance work is extremely simple and is reduced to a minimum.



## Quality guarantee

The WM Pinguino is a product which has been developed, built and assembled in house, from start to finish. Only by doing so can we guarantee top quality and punctual delivery times.



## Detailed operating instructions

You can find all information on operation, maintenance and safety in the operating manual.

## The right replacement part, every time

Order your spare parts easily and conveniently from our online portal *Blue Shop*: Our series number and digital image system enable you to find the part you need with just one click.



### Service and support

Our well-networked, international team of technicians undergo constant training and will be delighted to help you whenever you require assistance.



### Series production

All WM ice technics vehicles are series-manufactured. We know exactly which parts have been used in each series run, and can deliver the correct spare parts to you at all times. At the same time, a number of optionals can be retrofitted with minimum effort and maximum precision, even years later.

### Quality consciousness

From the manufacture of individual parts right through to the final quality-control inspection: Every step of the process is carried out and monitored with the utmost of precision. Each and every member of our staff is well-trained in his specialist field, and carries out all tasks conscientiously. This is a great advantage for our customers, who can be sure of receiving a technologically sophisticated product which has been manufactured to the very highest of quality standards.





www.wm-on-ice.com  
Italy

WM ice technics relies on the following distribution partners in North America:



**Autoworq**  
Montreal (Québec)  
Phone 1-866-973-1333  
www.autoworq.com



**LSK Enterprises**  
Virginia Beach (VA)  
Phone 1-757-366-0166  
www.lskenterprises.com



**Outdooricerinks.com**  
Strongsville (OH)  
Phone 1-440-628-7979  
www.outdooricerinks.com



Mobile / Event

Pro / Heavy duty



**Compact**



**evo**